

### PRODUCT DESCRIPTION

The LED Color and Wattage Tunable Back-Lit Flat Panel is a commercial LED panel light designed to easily replace traditional florescent troffers and offers three different color temperatures by simply adjusting a single switch. These panels can also be adjusted to consume more or less power to offer three different brightness levels. Moreover, these panels offer up to 60% energy savings and longer lifespan than traditional troffers. Suitable for: office spaces, commercial, retail and a variety of other indoor applications.

### FEATURES

- No LGP, never yellowing
- High efficacy up to 130 lm/W, meets DLC 5.0 standard and premium version
- 0-10V dimmable
- Color and Wattage tunable
- Easy installation
- 5 Year Warranty

### PERFORMANCE RATINGS AND CERTIFICATIONS

UL, DLC, FCC, RoHS listed

### PERFORMANCE SUMMARY

- Lumens:** 3125 - 5000
- Lumens per Watt:** 125
- CRI-Minimum:** >80
- CCT:** Cool White (5000K), Natural White (4000K), Warm White (3500K)
- Watts:** 25W - 40W
- Operating Environment:** -25°C to 40°C
- Optical Distribution:** 110° Beam Angle

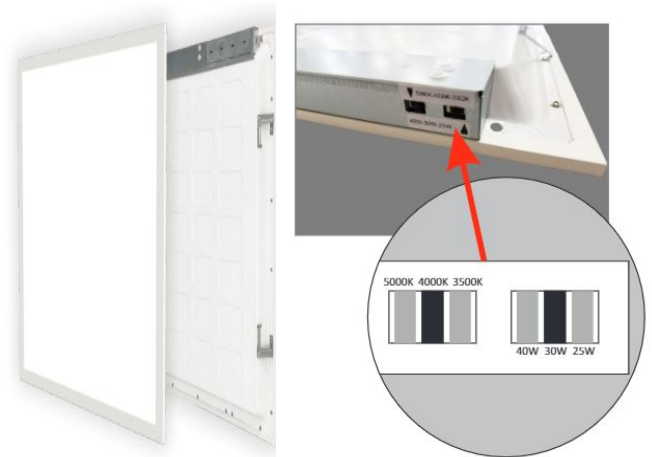

RoHS



### KIT INFORMATION

- Finish:** White frame
- Mounting:** Recessed, Surface Mount
- Dimensions:** 23.70" x 23.70"

### ELECTRICAL SYSTEM CHARACTERIZATIONS

- Voltage:** 120 - 277VAC, 50/60 Hz
- Dimming:** 0-10V dimming
- Power Factor:** >0.9
- Total Harmonic Distortion:** <20%

### WARRANTY

5 Year Standard Warranty Limited

## ORDERING MATRIX

**Example:** ST-FP22CT-MT-RC

Family	Product	Voltage	Mounting
ST	FP22CT = Color and Wattage tunable LED Back-Lit Flat Panel 2 x 2	MT = 120-277VAC 50/60 Hz	RC= Recessed Mount SM = Surface Mount

## PRODUCT DIMENSIONS

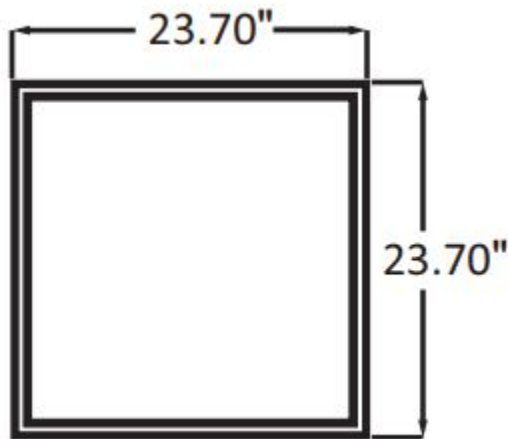

## WIRING DIAGRAM

